



G021970

Heat Detector

HC100 B

Part no. 038015

System: All Salwico Fire Alarm Systems

General Description

The HC100 B is a conventional heat detector. The detector is with its low profile and smooth design very suitable in locations with high architectural requirements such as offices, restaurants, hotel rooms and cabins.

The heat sensing element is of thermistor type with a short response time to changes in the ambient temperature. Alarms are optically indicated until they are reset on the central.

The detector is environmentally adapted in aspects of the selection of material and design.

The detector is polarisation independent (unless the remote output is used) which simplifies the installation. The mesh is very easy to change and clean which simplifies maintenance.

Data

Function	Conventional
Working voltage	16-30 VDC
Alarm temperature	80 °C
Classification	B, EN54-5:2000
Working current	< 25 µA
Alarm current	Max 54 mA
Remote output	Max 20 mA
Ingress protection	IP43/55 depending on base
Ambient humidity	95% at 55 °C
Temperature range	-10 °C to +70 °C
Material	PC/ABS
Colour	White
Weight	95 g ± 5%
Certified according to	 2531-CPR-232.1711 DoP no. 6301901

For information about suitable base plates, see separate document "Base matrix".

Connection

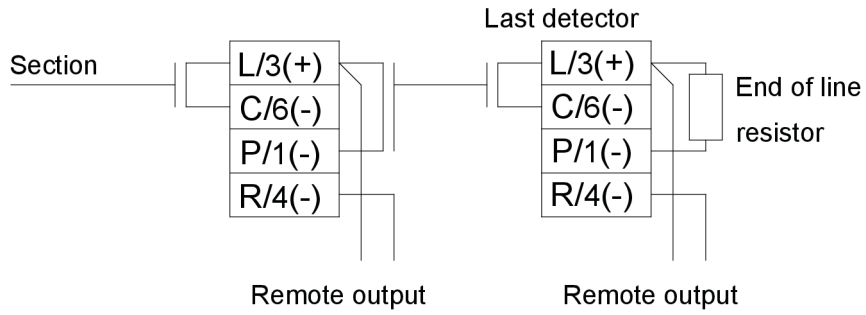

G021971

Dimensions (mm)

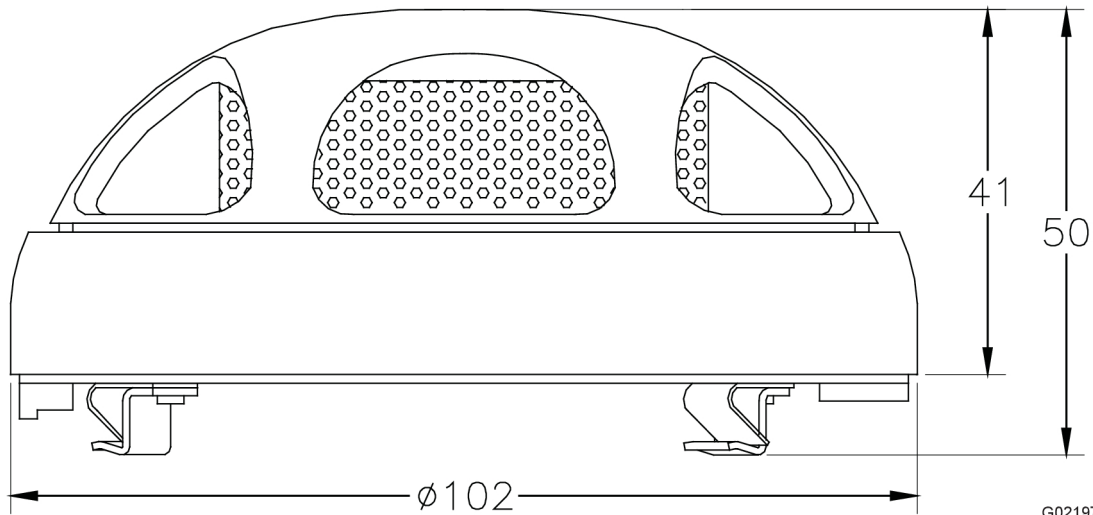

G021972